

### Features

Features	Code
Brake Caliper	H
Standard	W
With piston diameter 75 mm	075
Spring activated	F
Hydraulically released	H
Manual adjustment to counter friction block wear	M
Spring packages available for clamping forces of 10 kN, 20 kN, 30 kN, 40 kN or 55 kN	010 to 055

### Example for ordering

Brake Caliper HW 075 FHM, spring package for clamping force 10 kN:

HW 075 FHM - 010

52-1

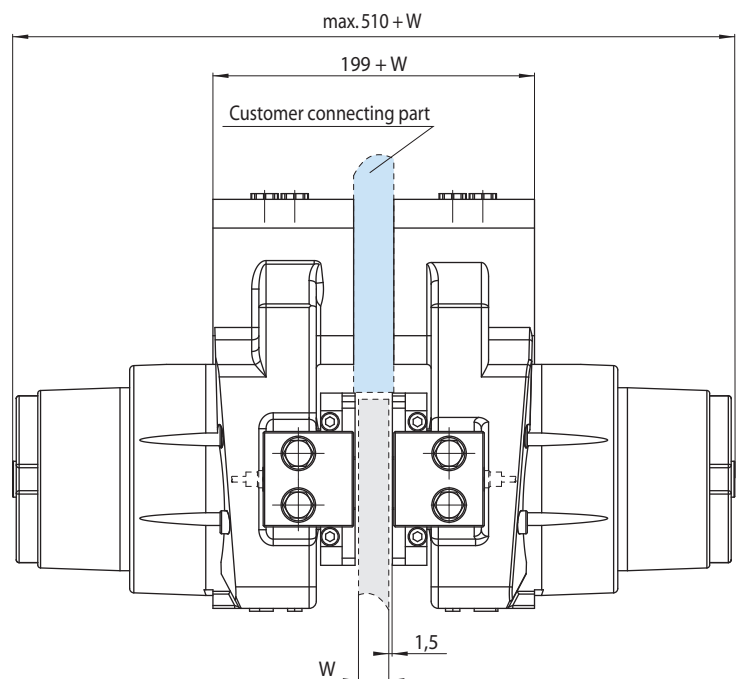
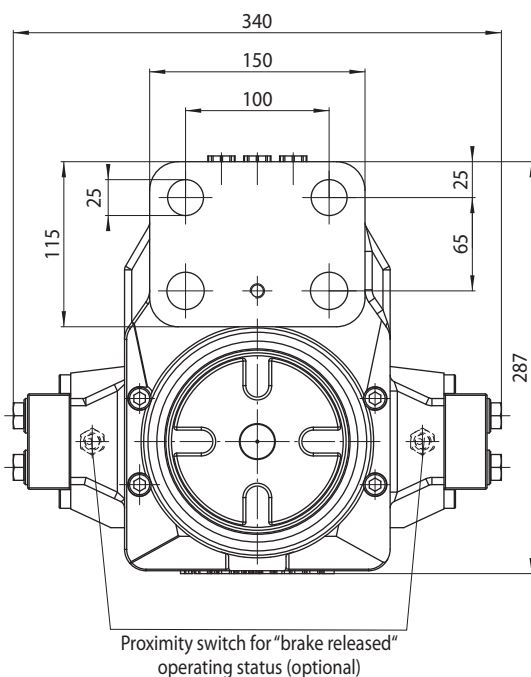

52-2

# Brake Caliper HW 075 FHM

spring activated – hydraulically released

Morskate®



## Mounting

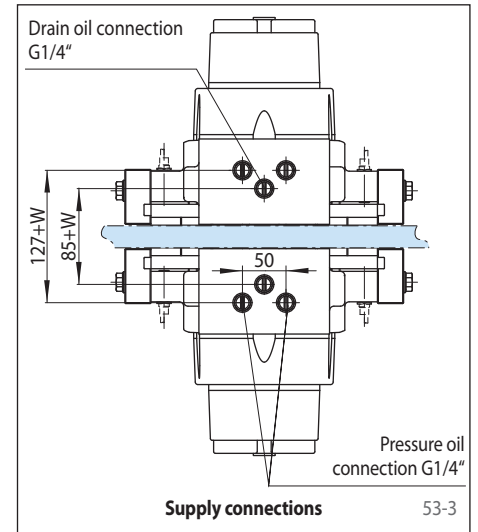
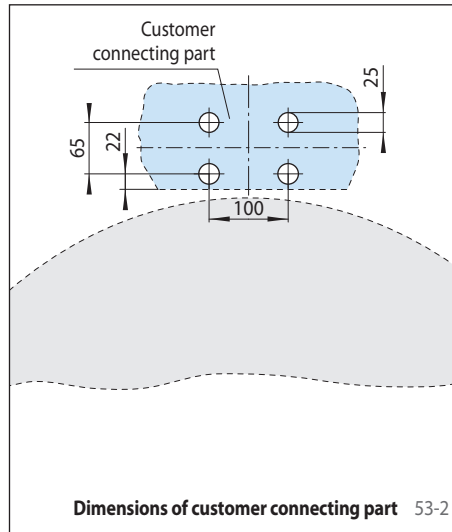
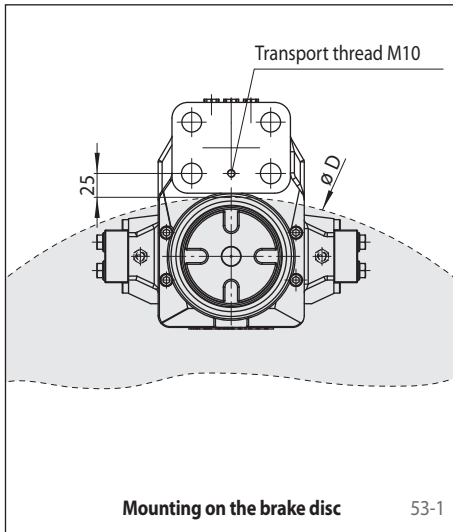

## Technical Data

	Brake Caliper HW 075 FHM				
	with spring package 010	with spring package 020	with spring package 030	with spring package 040	with spring package 055
Brake disc diameter	Braking torque	Braking torque	Braking torque	Braking torque	Braking torque
[mm]	[Nm]	[Nm]	[Nm]	[Nm]	[Nm]
630	1900	3800	5700	7600	10400
710	2200	4400	6600	8800	12100
900	3000	5900	8900	11900	16300
1250	4400	8700	13100	17500	24000
1600	5800	11500	17300	23100	31800
2000	7400	14700	22100	29500	40500
Clamping force	10 kN	20 kN	30 kN	40 kN	55 kN
Oil pressure	min. 25 bar max. 140 bar	min. 50 bar max. 140 bar	min. 70 bar max. 140 bar	min. 95 bar max. 140 bar	min. 125 bar max. 140 bar
Oil volume per stroke	max. 89 cm <sup>3</sup>	max. 89 cm <sup>3</sup>	max. 89 cm <sup>3</sup>	max. 89 cm <sup>3</sup>	max. 89 cm <sup>3</sup>
Weight	90 kg	90 kg	90 kg	90 kg	90 kg

The braking torques shown in the table are based on a theoretical friction coefficient of 0,4.

## Other features

- High safety against leakage
- Easy change of friction blocks
- Painted with surface coating class C4-L according to ISO 12944
- The thickness of the customer connecting part results from the thickness of the brake disc W plus 3 mm

## Accessories

- Inductive proximity switch for "brake released" operating status
- Optional painting with surface coating class C4-H or C5M-H (offshore) according to ISO 12944

Any questions? Please contact us.

### Morskate Aandrijvingen BV

Oosterveldsingel 47A  
7558 PJ Hengelo (Ov)  
The Netherlands

### NL

T +31 (0)74 - 760 11 11  
info@morskateaandrijvingen.nl  
www.morskateaandrijvingen.nl

### DE

T +49 692 - 222 34 95  
info@morskateantriebstechnik.de  
www.morskateantriebstechnik.de

### EN

T +31 (0)74 - 760 11 11  
info@morskatedrivetechnology.com  
www.morskatedrivetechnology.com